







NOTE1:

NOTE2:

### ELECTRICAL CHARACTERISTICS



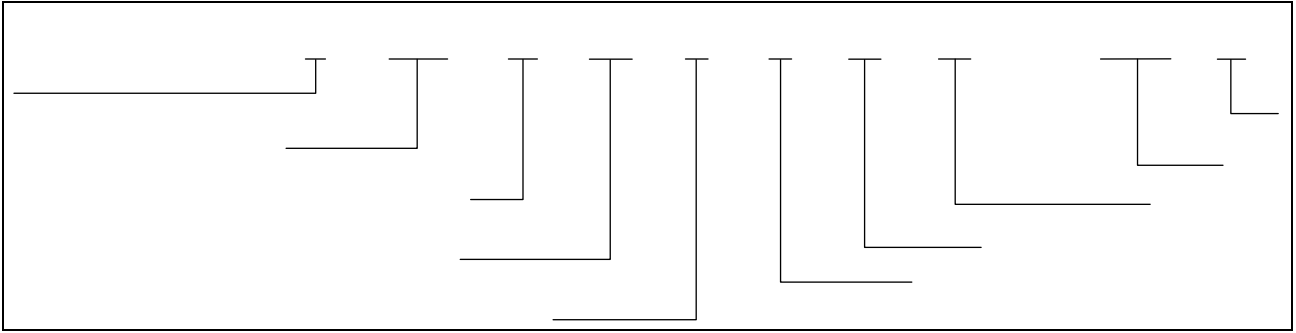

## ORDERING INFORMATION

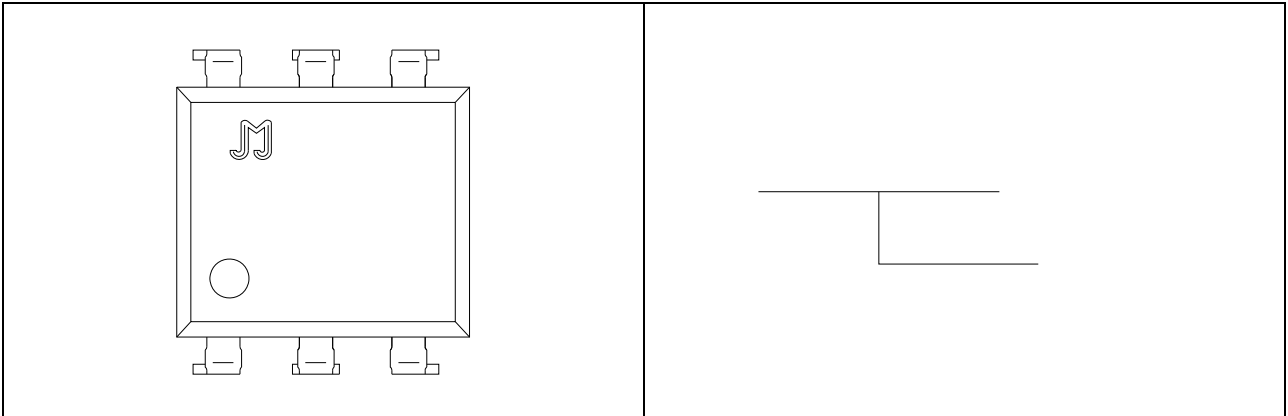

Packing Quantity	
Option	Quantity

## MARKING





## Characteristics Curves

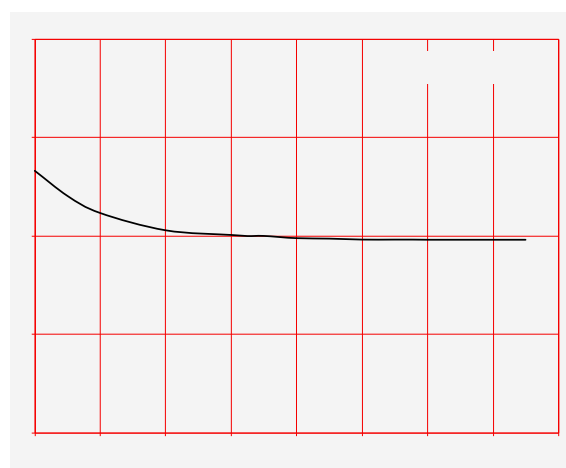
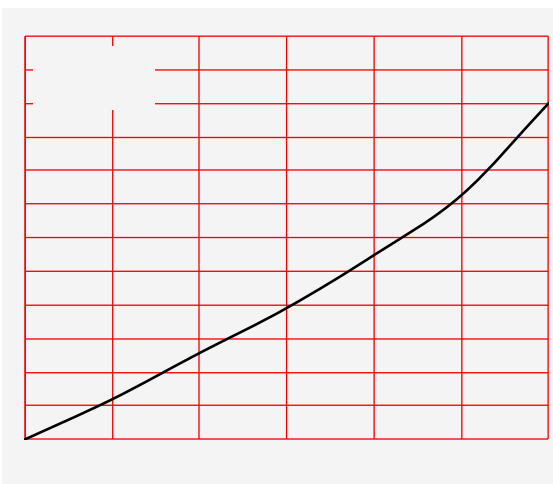
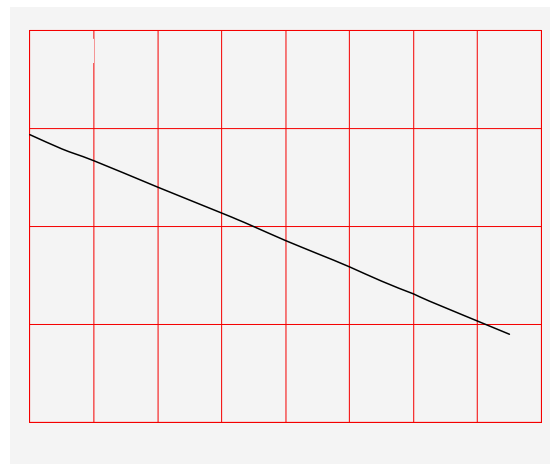
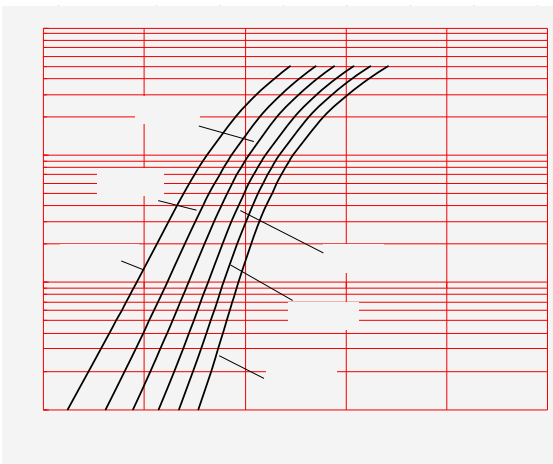
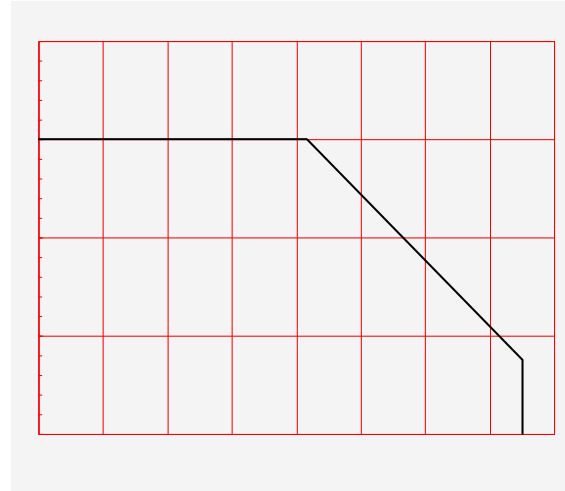
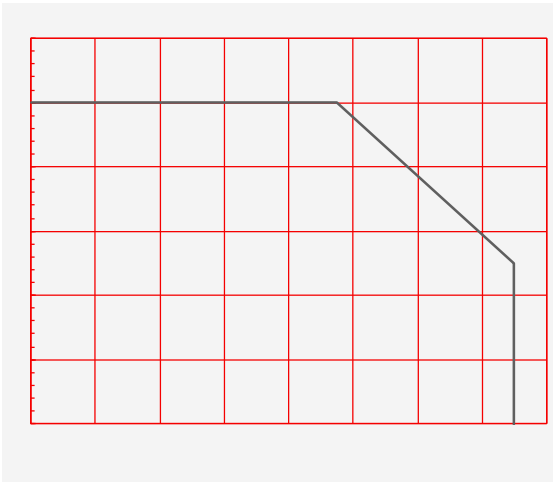

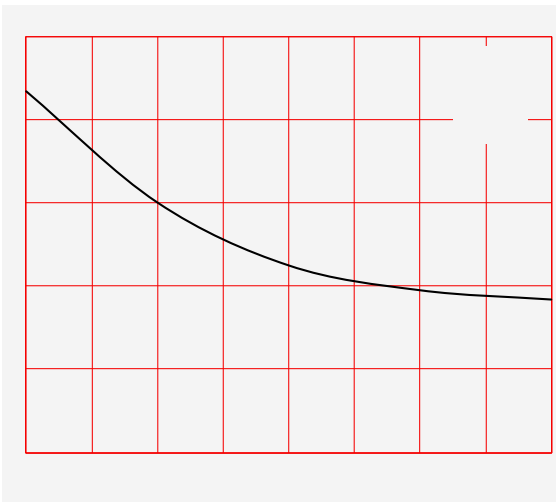
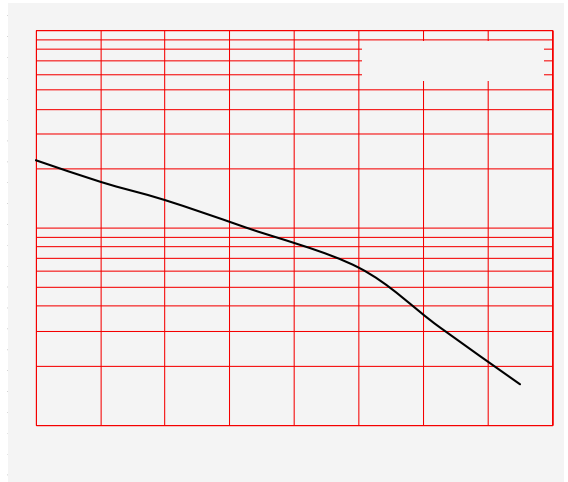
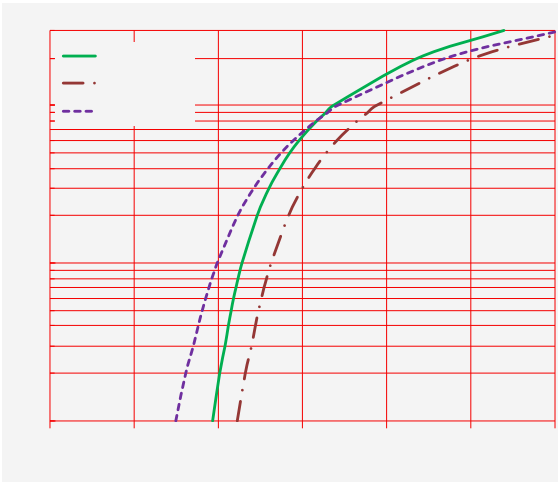



## TEST CIRCUITS

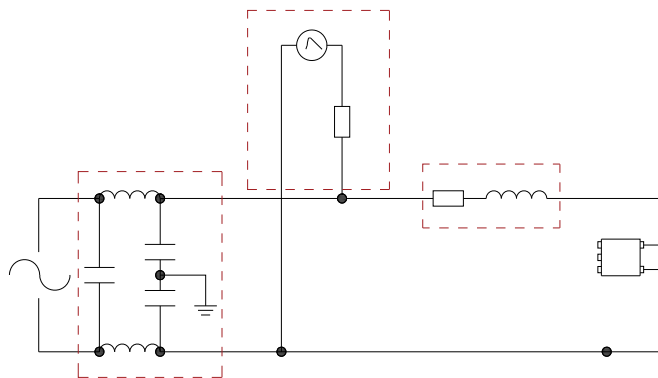
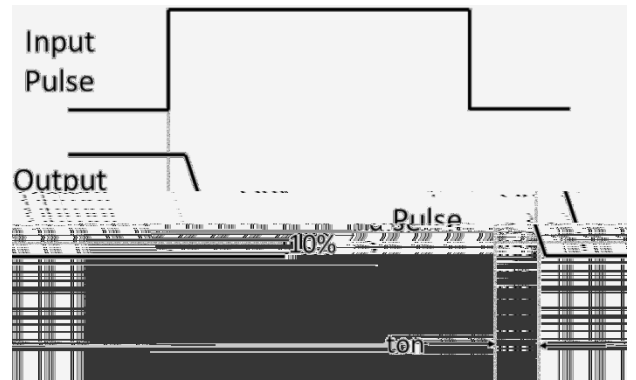
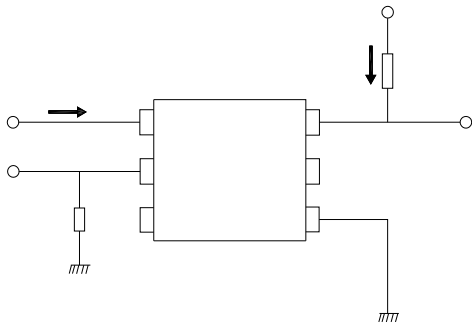





---

RECOMMENDED SOLDER MASK (Dimensions in mm unless otherwise stated)

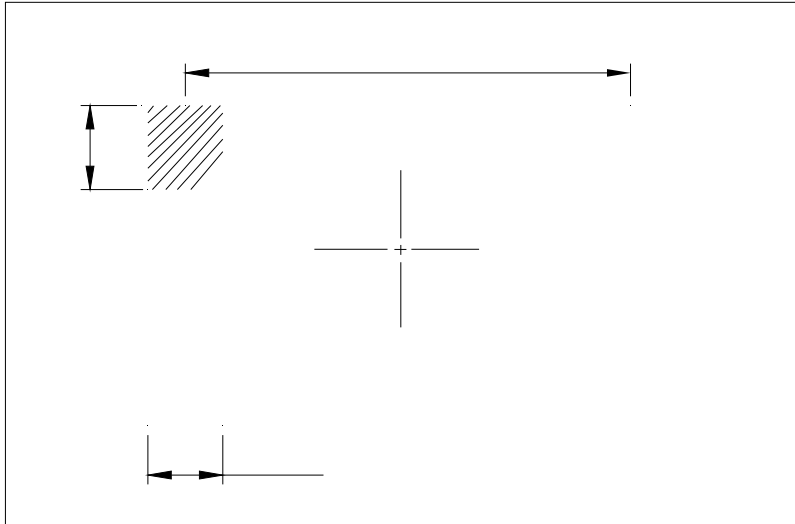





# REFLOW INFORMATION

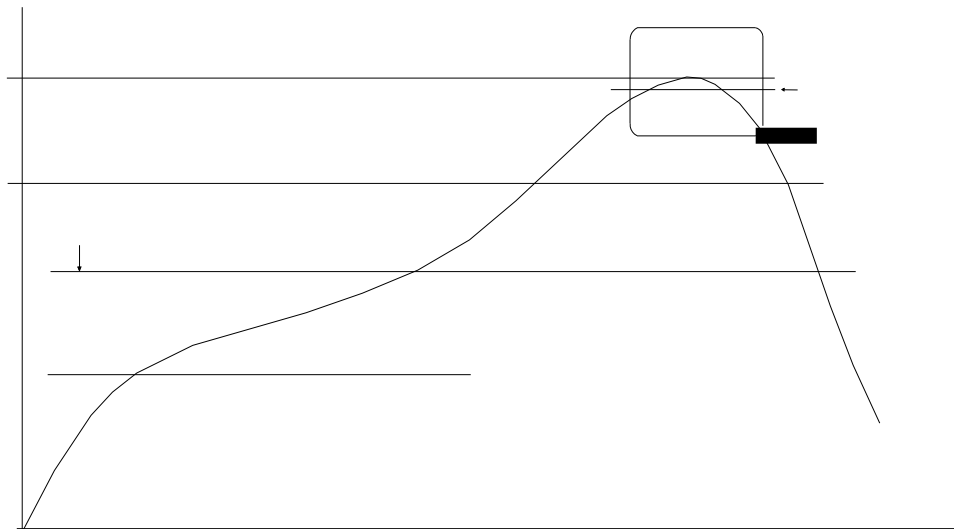
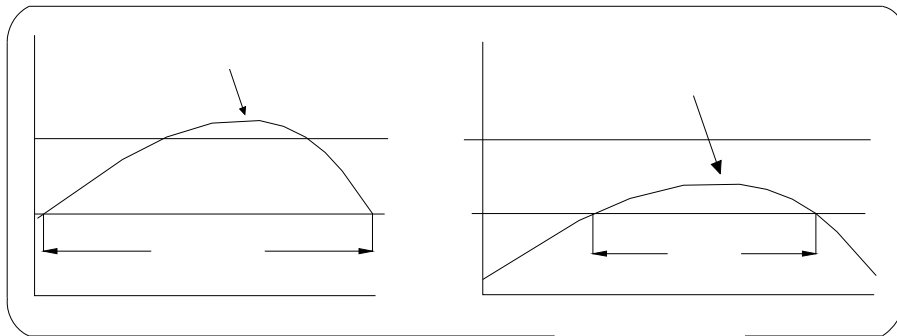



## WAVE SOLDERING

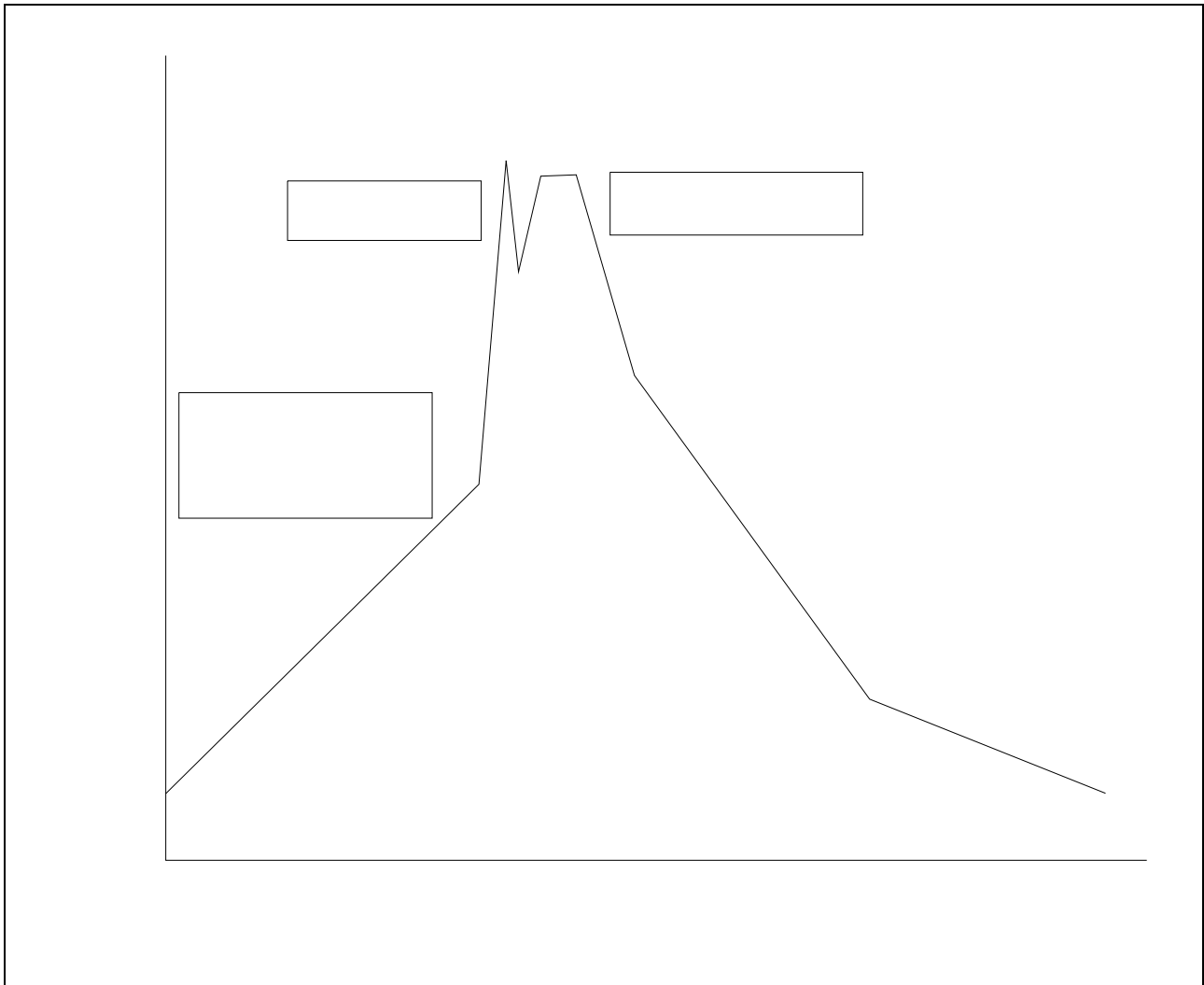

## HAND SOLDERING BY SOLDERING IRON

±

