

ORDERING INFORMATION

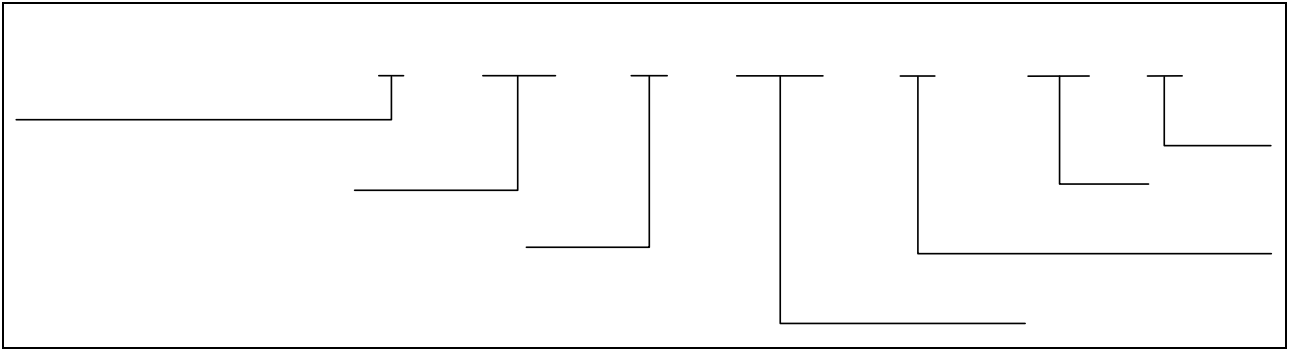

Packing Quantity	
Option	Quantity
None/R	3000 Units/Reel

MARKING

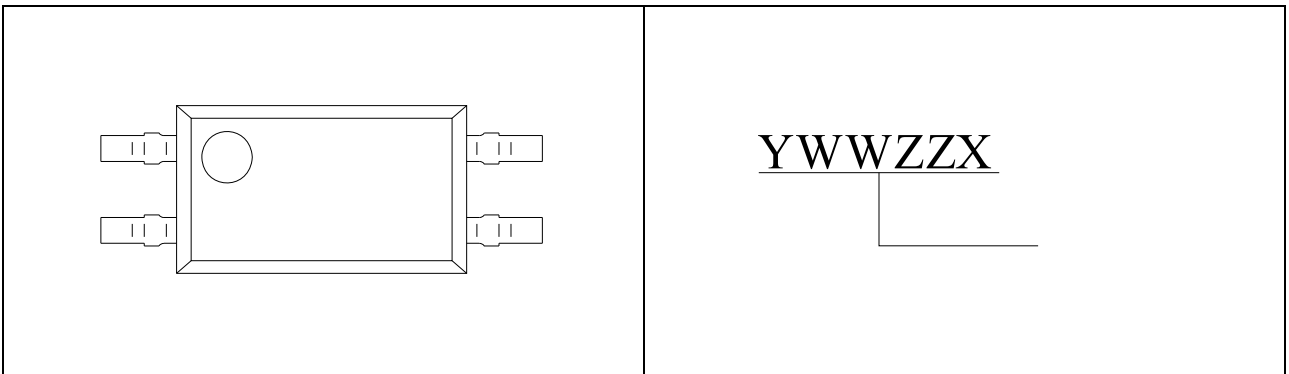

Characteristics Curves

FIG.1:

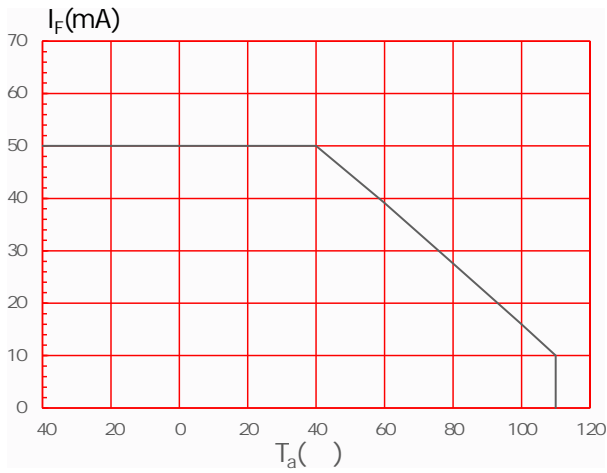

FIG.2:

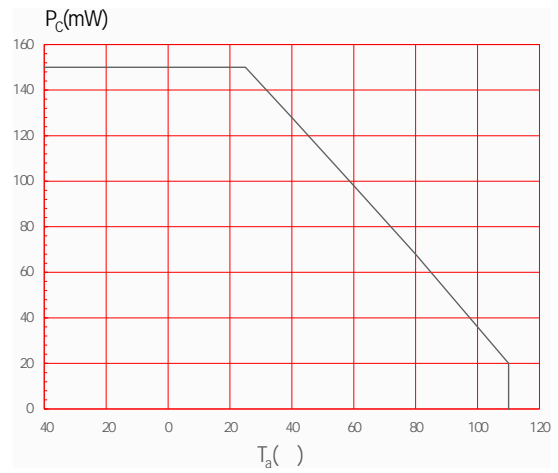

FIG.3:

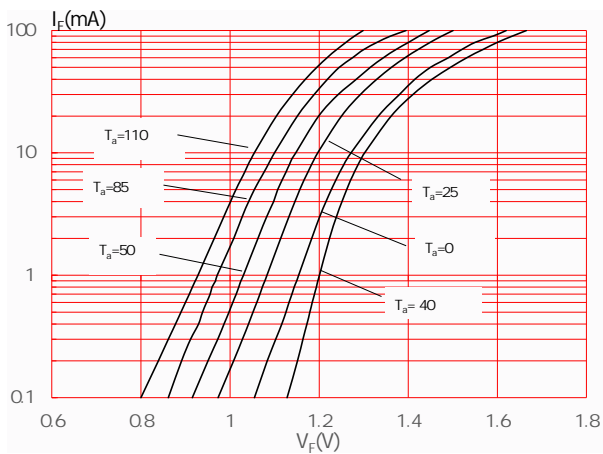

FIG.4:

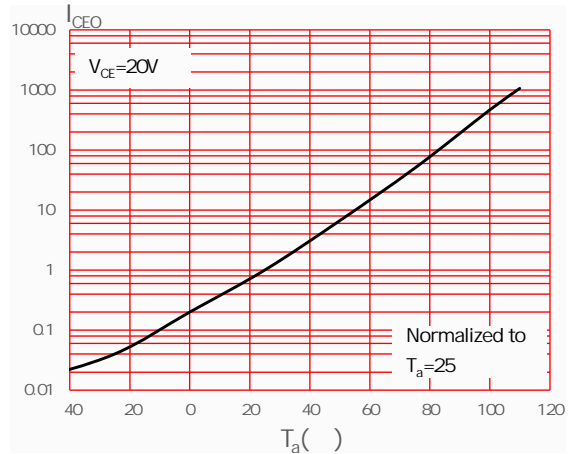

FIG.5:

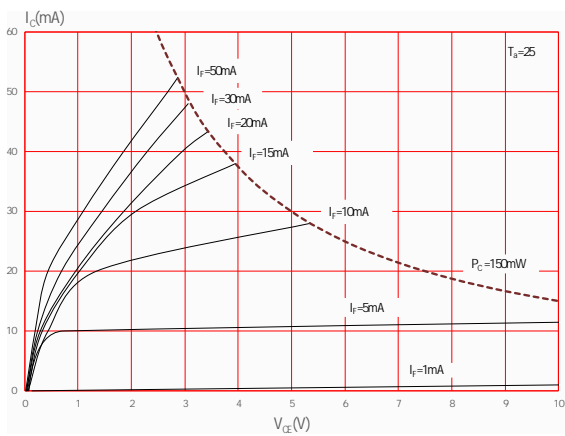

FIG.6:

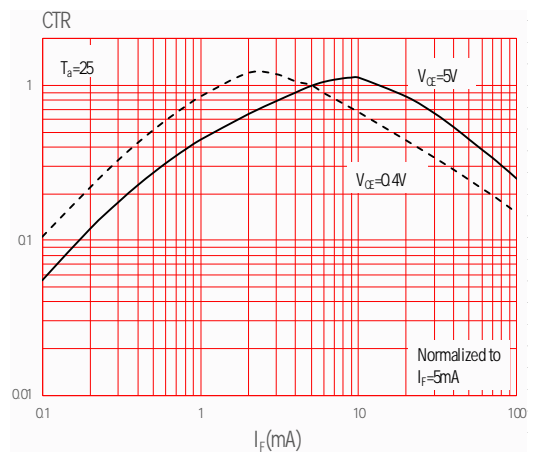

FIG.7:

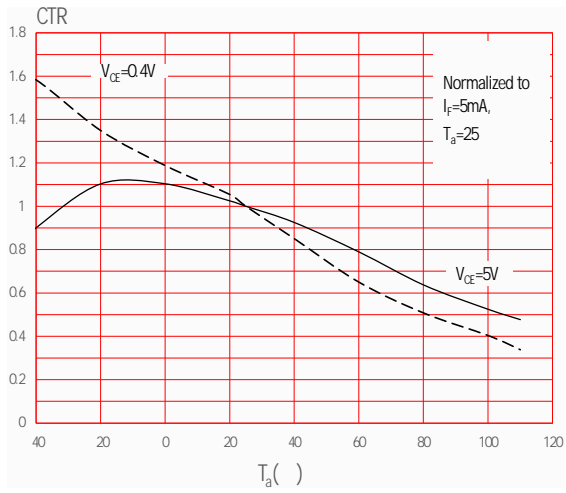

FIG.8:

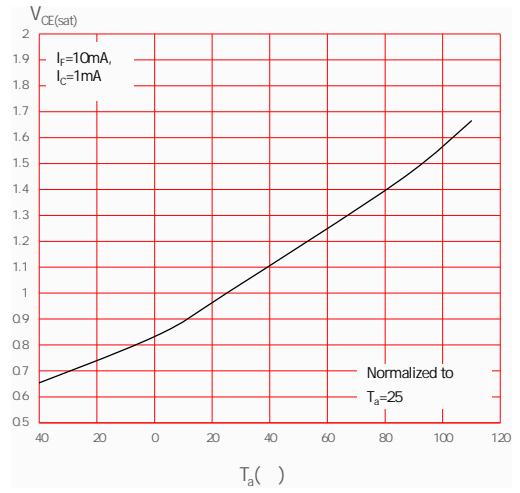

FIG.9:

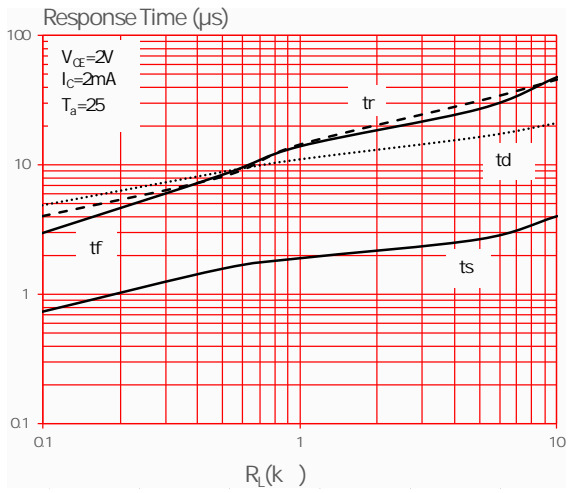
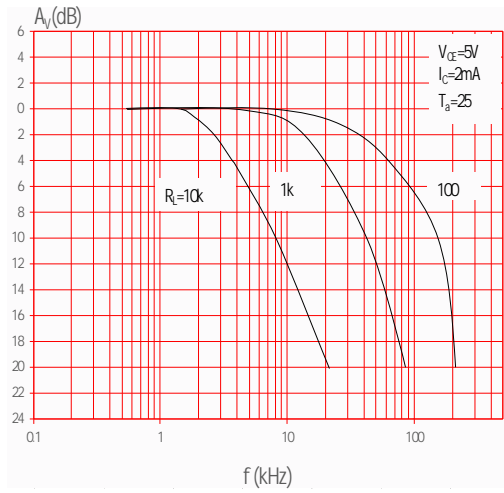

FIG.10:



Test Circuits

FIG.11:

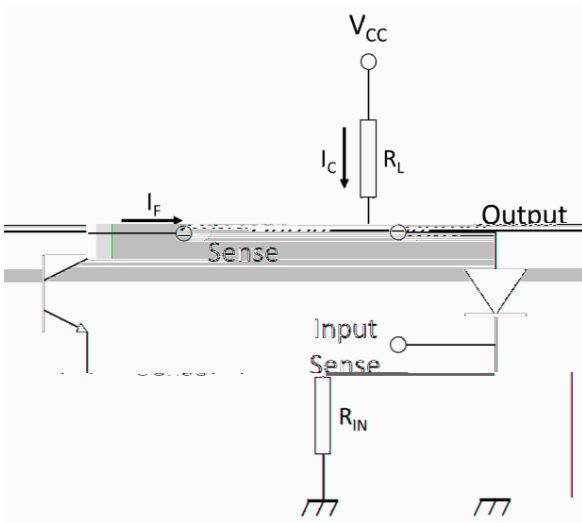

FIG.12:

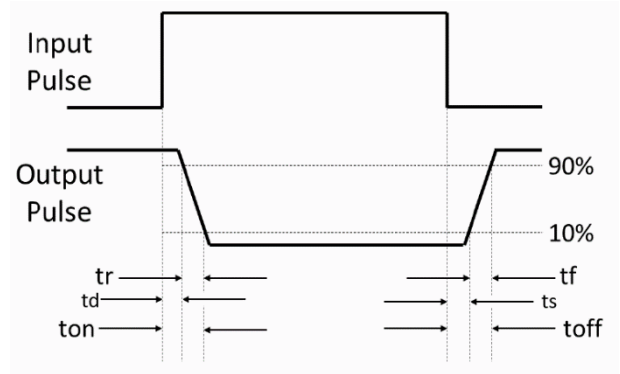
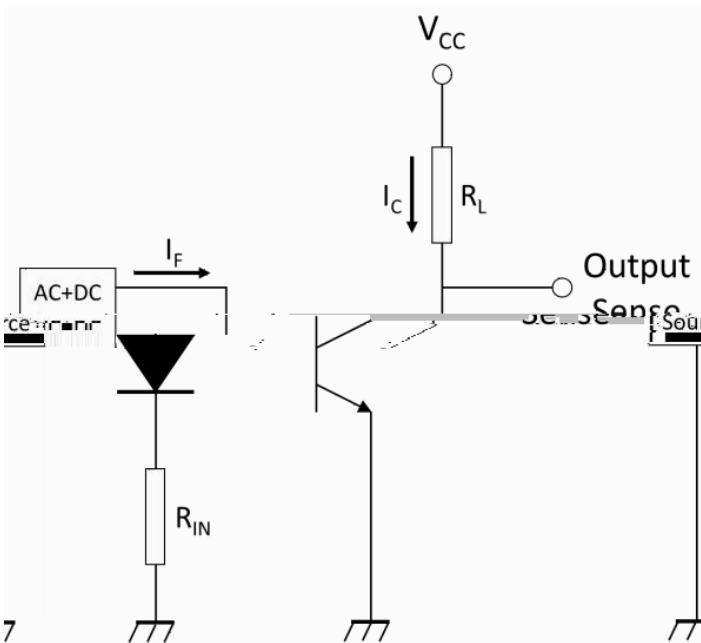

FIG.13:



CARRIER TAPE SPECIFICATIONS (Dimensions in mm unless otherwise stated)

Option None/R

